

# OUTLOOK

Visions and research directions for the Wireless World

2014, No 15



## LTE Small Cell Enhancement by Dual Connectivity

Working Group C  
“Communication Architectures and Technologies”

White Paper

---

**LTE Small Cell Enhancement  
by Dual Connectivity**

November 2014

---

Version 1.1

---

## Contributors

Full Name	Affiliation	Contact
Jian Zhang	Huawei Technologies, China	justincn.zhang@huawei.com
Qinghai Zeng	Huawei Technologies, China	zengqinghai@huawei.com
Mahmoodi, Toktam	King's College London, UK	toktam.mahmoodi@kcl.ac.uk
Andreas Georgakopoulos	University of Piraeus, Greece	andgeorg@unipi.gr
Panagiotis Demestichas	University of Piraeus, Greece	pdemest@unipi.gr

## Table of Contents

<b>0.</b>	<b>Abbreviation .....</b>	<b>5</b>
<b>1.</b>	<b>Purpose .....</b>	<b>6</b>
<b>2.</b>	<b>Scope.....</b>	<b>6</b>
<b>3.</b>	<b>Motivation.....</b>	<b>6</b>
3.1	Challenges.....	6
3.2	Motivations .....	7
3.3	Scenarios.....	7
<b>4.</b>	<b>Architecture .....</b>	<b>8</b>
4.1	Control plane architecture .....	8
4.2	User plane architecture .....	8
4.3	Backhaul aspects .....	10
<b>5.</b>	<b>Network interface .....</b>	<b>11</b>
5.1	S1 interface .....	11
5.2	X2 interface .....	11
5.3	Flow control .....	12
<b>6.</b>	<b>Control plane handling .....</b>	<b>12</b>
6.1	eNB Synchronization.....	12
6.2	Security handling.....	12
6.3	System information acquisition .....	12
6.4	SeNB radio resource management.....	13
6.5	Selection of connection at the UE .....	14
6.5.1	Use of Analytics.....	14
6.6	UE capability handling.....	14
6.7	SeNB radio link failure handling.....	14
<b>7.</b>	<b>User plane handling .....</b>	<b>15</b>
7.1	UL-DL split.....	15
7.2	UL bearer split .....	15
7.3	UCI transmission of SeNB.....	15
7.4	PDCP handling .....	16
7.5	RLC handling.....	16
7.6	UE MAC entity modeling .....	16
7.7	Random access.....	16
7.8	BSR procedure .....	17
7.9	LCP procedure .....	17
7.10	PHR procedure.....	18
7.11	DRX .....	19
7.12	Multi-Path TCP support.....	19
7.13	Activation/deactivation.....	19
<b>8.</b>	<b>Potential enhancements in future releases.....</b>	<b>19</b>
<b>9.</b>	<b>Summary .....</b>	<b>19</b>
<b>10.</b>	<b>References .....</b>	<b>20</b>

## Executive Summary

### The WWRF and WGC

The White Paper on “LTE Small Cell Enhancement by Dual Connectivity” is the outcome of discussions and suggestions in the context of the Wireless World Research Forum (WWRF) meetings and the Working Group C (WGC) in particular, which handles issues related to “Communication Architectures and Technologies”.

### LTE small cell enhancement by dual connectivity towards 5G evolution

Framed in this context, the paper describes the common vision on small cell enhancement by dual connectivity. Small cells are becoming a promising technology to meet ever increasing traffic capacity and data rate demand. Small cells are typically deployed as hotspots within macro cell coverage. By enhancing small cells by dual connectivity certain benefits are anticipated such as:

- ✓ Increased UE throughput especially for cell edge UEs;
- ✓ Mobility robustness enhancement;
- ✓ Reducing signaling overhead towards the core due to frequent handover.

### Architecture and technical considerations

In this respect, the White Paper elaborates on the architecture of dual connectivity where the UE can receive/transmit data from/to multiple eNBs simultaneously. There is a Master eNB (MeNB) and one or more Secondary eNBs (SeNB). In LTE release 12 specifications, only the case of one MeNB and one SeNB is considered. For the support of dual cell connectivity, some modifications to existing S1 interface and X2 interface are needed as well and these aspects are elaborated on Chapter 5. Finally technical considerations regarding the control and user planes are presented in sections 6 and 7 respectively.

### Proposed enhancements for LTE R-12 and beyond

LTE small cell enhancement by dual connectivity is a technology which extends carrier aggregation (CA) and coordinated multi-point (CoMP) to inter-eNB with non-ideal backhaul while LTE release 12 focuses on inter-eNB CA case for per UE throughput improvement and mobility robustness. Specifically, Chapter 8 of this White Paper discusses ‘Potential enhancements in future releases’ where ultra-dense infrastructure deployments, utilization of mmWave bands, multiple antennas, integrated use of M2M communications with ultra-low latency and very high reliability will set the requirements of future releases towards 5G.

### Way Forward

More White Papers related to innovations in the field of “Communication Architectures and Technologies” will follow in order to address sufficiently several trending topics on: Management of evolved RATs; Ultra-Dense Networks; Dynamic/Flexible Spectrum Management and Spectrum Sharing; Virtualization of Infrastructure by exploiting the concepts of Software-Defined Networking (SDN) and Network Function Virtualization (NFV); Cloud-RANs.

## 0. Abbreviation

AP	Access Point
CA	Carrier Aggregation
CCE	Control Channel Element
CN	Core Network
CoMP	Coordinated Multi Point
CRE	Cell Range Extension
DC	Dual Connectivity
DRX	Discontinuous Reception
eNB	eNode B
HO	Handover
LTE	Long Term Evolution
MAC	Medium Access Control
MCG	Master Cell Group
MME	Mobility Management Entity
MeNB	Master eNB
NAS	Non-Access Stratum
NGMN	Next Generation Mobile Networks
OPEX	Operational Expenditures
PCRF	Policy and Charging Rules Function
PDCCH	Physical Downlink Control Channel
PSCell	Primary SCell
QoS	Quality of Service
RAN	Radio Access Network
RAT	Radio Access Technology
RBG	Resource Block Group
RNC	Radio Network Controller
Rx	Receiver
SCE	Small cell enhancement
SCG	Secondary Cell Group
SeNB	Secondary eNB
SI	Study Item
SON	Self-organizing network
TCH	Traffic Channel
TDD	Time Division Duplexing
Tx	Transmitter
UE	User Equipment
UMTS	Universal Mobile Telecommunications System
WI	Work item

## 1. Purpose

This paper introduces the 3GPP progress of LTE small cell enhancement (SCE) – higher layer aspects study item (SI) [1] and its corresponding work item (WI): dual connectivity (DC) [2]. The SCE SI is completed in December 2013, and the corresponding WI was created. Multiple Rx/Tx capable UE in inter-frequency scenario is prioritized in the WI.

## 2. Scope

This paper focuses on the architecture and key technologies introduced in LTE DC to improve radio resource efficiency and mobility robustness. It mainly consists of 5 parts

Chapter 3: motivation

Chapter 4: architecture

Chapter 5: network interface

Chapter 6: control plane handling

Chapter 7: user plane handling

## 3. Motivation

### 3.1 Challenges

Small cells are becoming a promising technology to meet ever increasing traffic capacity and data rate demand. Small cells are typically deployed as hotspots within macro cell coverage. Backhaul between low power nodes providing small cells and macro nodes may be ideal and non-ideal. Existing intra-eNB CA and CoMP architectures assume ideal backhaul in which centralized scheduling can be implemented for efficient radio resource utilization. LTE release 12 SCE SI concerns inter-eNB CA and CoMP operations with non-ideal backhaul. Inter-eNB CoMP scenario is mainly studied in a separate study item [3]. For inter-eNB CA and CoMP with non-ideal backhaul, distributed resource allocation and coordination have to be relied upon and new challenges emerge, e.g.:

- *Efficient radio resource utilization across eNBs*

Difficult to improve per-user throughput by utilizing radio resources in more than one eNBs with non-ideal backhaul while taking QoS requirements into account;

- *Mobility robustness*

Mobility robustness in inter-frequency scenario is not as good as in a macro only network, but less of a problem than in co-channel scenario if no DRX is used;

- *Increased signalling load*

Signalling over X2 interface as well as signalling towards the MME and the S-GW is increased with increasing UE speed due to frequent handover;

- *UL/DL imbalance between macro and small cells*

UE's best uplink cell and best downlink cell may be different. It is less of an issue for inter-frequency scenario than for co-channel case. Cell Range Extension (CRE) may be used for the latter case.

### 3.2 Motivations

Considering these new challenges, the SCE SI is mainly based on the follow motivations:

- *Increase UE throughput especially for cell edge UEs*

LTE DC can significantly increase the UE throughput especially for cell edge UEs by transmitting/receiving multiple streams and dynamically adapting to the best radio conditions of multiple cells. Small cells provide additional capacity for UEs having multiple radio connections.

- *Mobility robustness enhancement*

In heterogeneous network deployment, moving UEs suffers frequent handover failure, inefficient offload and service interruption due to short Time-of-Stay. The consequences are more severe if UE's velocity is higher and cell coverage is smaller. LTE DC can greatly reduce the handover failure rate by maintaining the macro cell connection as the coverage layer.

- *Reducing signaling overhead towards the CN due to frequent handover*

This can be achieved by not issuing handover operations as long as the UE is within macro coverage. Signaling generated towards the CN should be reduced as much as possible if the mobility only happens between small cells. Appropriate LTE DC architecture is the key for this purpose, e.g. only one S1-MME for the UE with the MME, as will be discussed later.

### 3.3 Scenarios

LTE DC can be deployed in the following 3 typical scenarios as depicted in figure 1; the aggregated serving cells of the involved eNBs can be intra-frequency or inter-frequencies. LTE DC is usually configured for low to medium mobility speed cases, and support indoor and outdoor, ideal and non-ideal backhaul scenarios. The focus is on non-ideal backhaul case.

- *Scenario 1: co-channel scenario*
- *Scenario 2: inter-frequency scenario*
- *Scenario 3: small cell out of coverage of macro cell scenario*

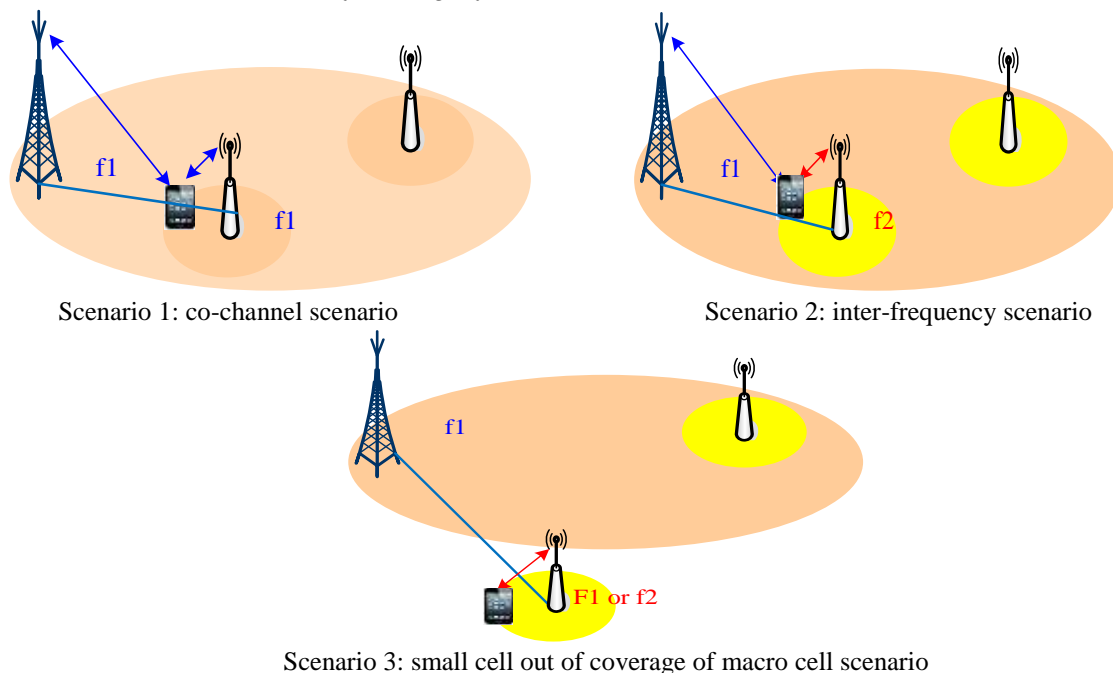

Figure 1: LTE DC typical scenarios



## 4. Architecture

In LTE DC, the UE can receive/transmit data from/to multiple eNBs. There is a Master eNB (MeNB) and one or more Secondary eNBs (SeNB). In LTE release 12 specifications, only the case of one MeNB and one SeNB is considered.

### 4.1 Control plane architecture

There is only one S1-MME connection per UE and it is terminated at the MeNB. The main purpose is to reduce signaling overhead towards the CN in case of SeNB change. The UE RRC connection is terminated only at the MeNB to reduce RRM and signaling complexity. There is no RRC entity in the SeNB. SeNB related RRC configurations are transmitted to the MeNB in the form of RRC container. MeNB makes final decision and constructs the eventual RRC configuration message and transmits it to the UE. The UE always maintains RRC connection with the MeNB as long it is under the macro cell coverage. This kind of control plane and user plane split architecture can avoid frequent handover and reduce handover failure rate. RRC diversity, i.e. both the MeNB and the SeNB may transmit RRC messages to the UE to improve signaling robustness, is discussed in 3GPP however not adopted in LTE release 12 due to its potential complexity. The control plane architecture is depicted in Figure 2.

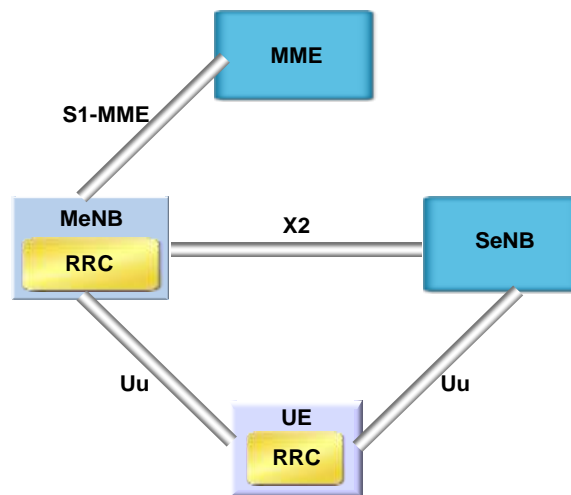

Figure 2: control plane architecture

### 4.2 User plane architecture

There are many possibilities of user plane architecture. User traffic may split at the S-GW or at the MeNB. Only bearer level split is possible in the S-GW where different E-RABs for the UE are routed by the MeNB and the SeNB respectively. Both the MeNB and the SeNB have S1-U connection with the S-GW for the UE. Both Bearer level and packet level split can be supportable if split takes place at the MeNB, and only one S1-U interface via the MeNB is needed. For the bearer level split, all user data of a radio bearer are routed between the SeNB and the UE. For the packet level split, user data may be routed between MeNB or SeNB and the UE. User data may be split as IP packets i.e. PDCP SDUs, PDCP PDUs, RLC PDUs etc. It is difficult to be split as MAC PDUs due to non-ideal backhaul and that MAC PDUs are generated in real time according to radio conditions at that TTI. 3GPP Rel-12 adopts the user plane architecture of bearer level split at the S-GW and PDCP PDUs level split at the MeNB, i.e. UP architecture 1A and 3C [4]. The architectures are depicted in figure 3 and figure 4 respectively. In Figure 4, it is also possible that all PDCP PDUs of bearer 2 are routed by the SeNB and in Rel-12, only RLC-AM type bearer split is considered.

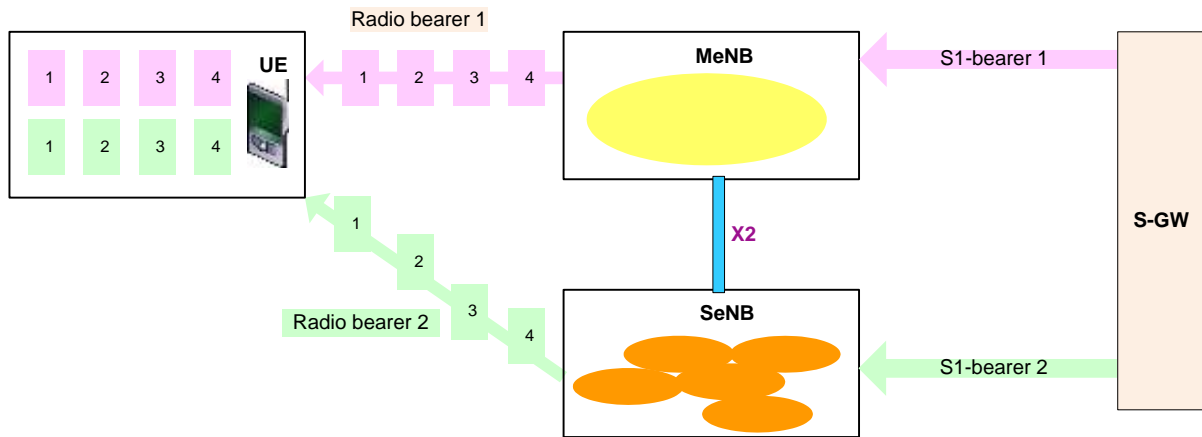

Figure 3: UP 1A - Bearer level split at S-GW

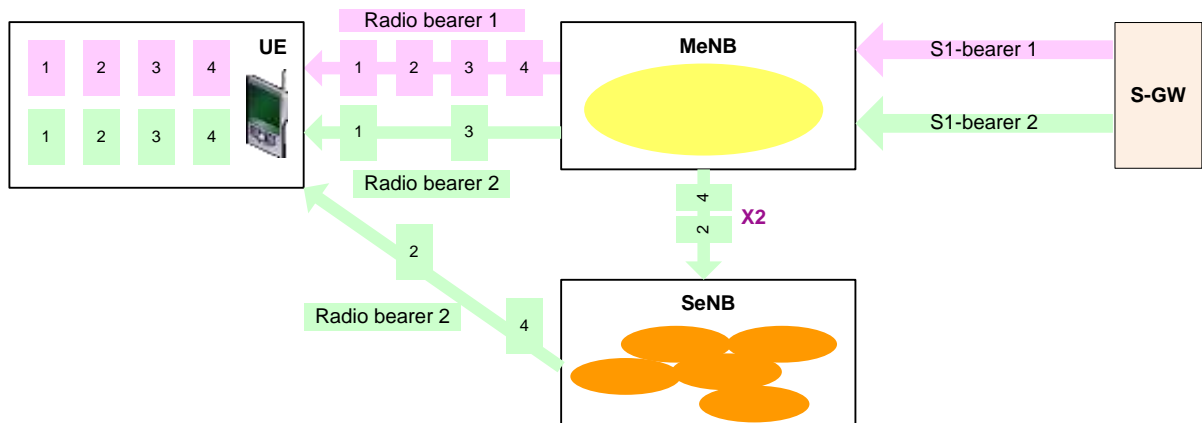

Figure 4: UP 3C - Packet level split as PDCP PDUs at MeNB

Table 1 shows pros and cons for the above user plane architectures.

**Table 1 Comparison of user plane architectures**

	<b>Alt1: UP 1A</b>	<b>Alt2: UP 3C</b>
<b>Pros</b>	<ul style="list-style-type: none"> <li>MeNB needs not buffer traffic for an EPS bearer of SeNB</li> <li>limited impact on PDCP/RLC and GTP-U/UDP/IP</li> <li>low requirements on the backhaul link between MeNB and SeNB</li> </ul>	<ul style="list-style-type: none"> <li>SeNB mobility hidden to CN</li> <li>no security impacts with ciphering being required in MeNB only</li> <li>no data forwarding between SeNBs required at SeNB change</li> </ul>
<b>Cons</b>	<ul style="list-style-type: none"> <li>SeNB mobility visible to CN</li> <li>security impacts due to ciphering being required in both MeNB and SeNB</li> </ul>	<ul style="list-style-type: none"> <li>need to route, process and buffer all dual connectivity traffic in MeNB</li> <li>PDCP reordering needs to be always on</li> <li>flow control required between MeNB and SeNB</li> </ul>

### 4.3 Backhaul aspects

A typical backhaul deployment scenario is that user traffic of the MeNB and the SeNB are aggregated and split at a higher level site, e.g. at a router between EPC and eNBs as depicted in figure 5. Backhaul capacity requirement of SeNB does not impact that of MeNB for UP 1A, but imposes additional requirement on that of MeNB for UP 3C. For example, the aggregation site needs to route forth and back from the MeNB for the user traffic destined to the SeNB.

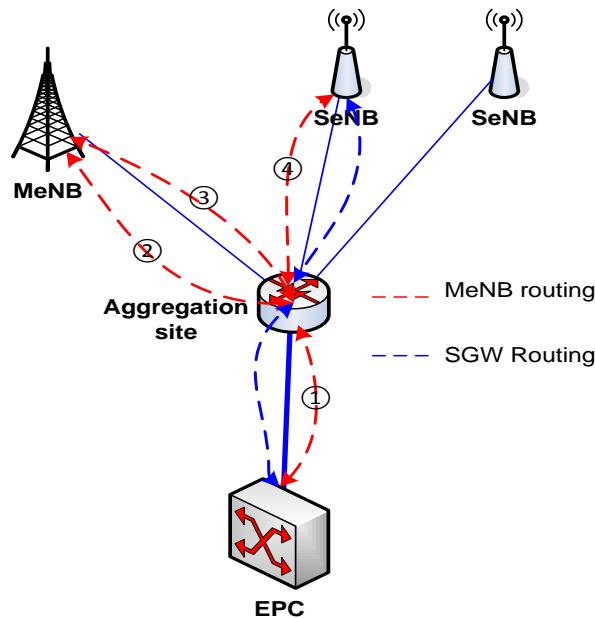

Figure 5: Higher level aggregation site than MeNB

Another typical backhaul deployment scenario is that user traffic of the MeNB and the SeNB are aggregated and split at the MeNB, as depicted in figure 6. In this scenario, the impact on MeNB backhaul by backhaul capacity requirement of SeNB is the same for both the UP 1A and UP 3C.

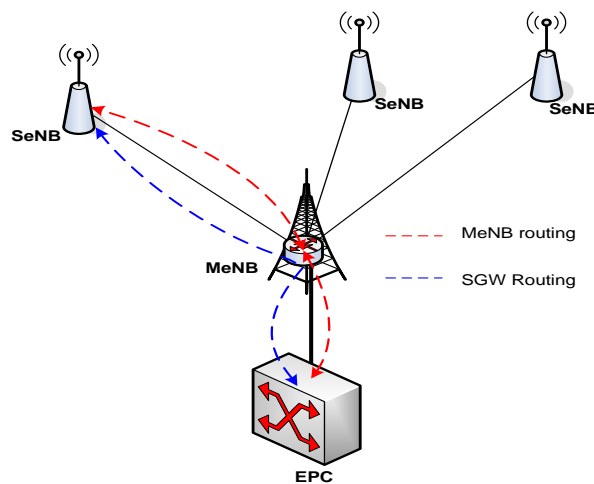

Figure 6: Aggregation site is the MeNB

## 5. Network interface

Some modifications to existing S1 interface and X2 interface are needed to support DC.

### 5.1 S1 interface

In LTE DC architectures, there is only one S1-MME interface between the MeNB and the MME. Depending on UP 1A or UP 3C, two S1-U interfaces or one S1-U interface are needed. For both UP 1A and UP 3C, S1-MME is not visible to the SeNB and the MME is not aware of the presence of SeNB. For E-RAB management function for UP 1A, the MeNB needs to initiate path switch procedure when E-RAB establishment or modification signaling is received from the MME. The MeNB decides which E-RABs are to be established in the SeNB and requests the MME to issue path switch operation. If legacy path switch procedure is used, an indication should be included to inform the MME that only some of the bearers need to be switched. In order not to impact existing specifications too much, a new procedure for partial path switch is considered, as depicted in figure 7. For UP 3C the MeNB provides its own GTP endpoint addresses for the bearers split into the SeNB so that the SeNB can transfer uplink PDCP PDUs according to the address. In the initial context setup procedure and the E-RAB establishment procedure, the MeNB also indicates the MME the downlink TNL information of the MeNB or both the MeNB and the SeNB depending on whether it is UP 3C or UP 1A.

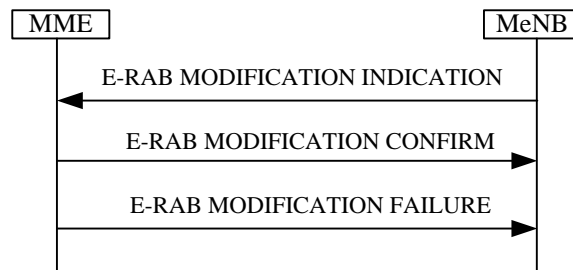

Figure 7: E-RAB modification for partial path switch

### 5.2 X2 interface

Existing X2 interface needs to be extended to support DC. X2 user plane new functions are responsible for PDCP PDU transmissions for UP 3C and data forwarding for UP 1A upon SeNB change or MeNB handover. SeNB provides feedback on PDCP PDUs delivery status e.g. the highest successfully transmitted PDCP PDU SN (sequence number) to the MeNB. Packet loss over X2 also needs to be aware by the MeNB, X2-U SN is introduced so that SeNB can report to MeNB packet loss over the air and X2 separately. The new X2-AP functions for DC are used to establish, modify and release UE context at the SeNB:

SeNB (SCG) Addition: used to add radio resources of a SeNB, initiated by the MeNB.

SeNB (SCG) Modification: used to modify radio resource configuration of SeNB, may be triggered by the MeNB or the SeNB.

SeNB (SCG) Release: used to release UE specific context at the SeNB, may be triggered by the MeNB or the SeNB.

SeNB (SCG) Change: This procedure can be realized by SeNB Addition/Modification procedure in which the source SeNB is released and the target SeNB is added.

Flow control function over X2 is beneficial for UP 3C to have more efficient rate control across eNBs and avoid congestion in the SeNB.

X2 signalings to support mobility operations in LTE DC are needed. **SeNB change** while keeping the MeNB can be implemented by the combination of SeNB addition and SeNB release. Downlink data forwarding from source SeNB to MeNB is needed for UP 1A, but not necessary for UP 3C because the MeNB can maintain copies of all packets transmitted to SeNB. Uplink data forwarding is needed for both architectures. Path switch

related signalings are needed for both UP 1A and UP 3C.

**MeNB change** can reuse existing handover procedure with slight updates and resources of SeNBs are released in the MeNB change procedure. SN status transfer and data forwarding are performed from the SeNB to the source MeNB, and then from the source MeNB to the target MeNB.

### 5.3 Flow control

For UP 3C, flow control between MeNB and SeNB is needed to avoid buffer overflow and packet losses at the SeNB. Mechanisms similar to existing flow control in UMTS Iub interface can be considered. SeNB can grant certain amount of capacity/buffer size to the MeNB periodically or based on the radio resource monitoring status. SeNB can indicate the buffer size on per UE basis or per bearer basis. MeNB may also be able to request SeNB for capacity allocation. New GTP-U extension header is introduced for the inter-eNB RRC container to transfer flow control information..

## 6. Control plane handling

### 6.1 eNB Synchronization

It is not required for the MeNB and SeNB to be SFN synchronized, not like the carrier aggregation (CA) case in which the aggregated serving cells from the same eNB are strictly SFN synchronized. The UE may only need to obtain SFN of one special cell in the SeNB, i.e. the always activated cell with configured PUCCH. To obtain the SFN information, the UE may read MIB of this special cell, or the MeNB informs SFN offset of the special cell to the UE by dedicated signaling.

### 6.2 Security handling

In LTE DC, the data transmitted via X2 interface and the new Uu interface between the SeNB and the UE should be encrypted. For UP 1A, the user plane encryption key in the MeNB and the encryption key in the SeNB will be cryptographically separated. MeNB derives a base-key (S-KeNB) from the currently active KeNB and sends it to SeNB over X2. The SeNB derives its user plane encryption key from the received S-KeNB.

### 6.3 System information acquisition

In Rel-10 and Rel-11 CA technology, system information of all SCells is configured to the UE by dedicated RRC signaling. This applies to initial system acquisition and system information update. In LTE DC, similar mechanism is reused. System information of small cells on SeNBs is firstly transferred to the MeNB in the RRC container via X2 interface and then configured to the UE by RRC signaling, as depicted in figure 8. This may contain SFN offset between the MeNB and the SeNB if they are not synchronized. Ambiguous time due to backhaul latency can be avoided by an indication of configuration complete information from the MeNB to the SeNB. Other means are also possible, e.g. UE acquires MIB and potentially also SIs of a special cell with configured PUCCH on the SeNB. However, additional complexity or requirements will be introduced and it may make these other means unnecessary.

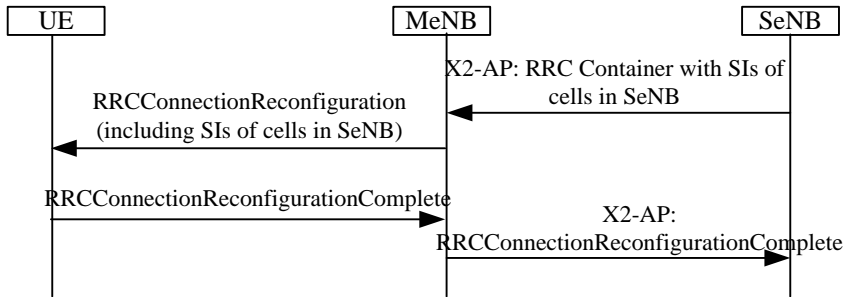

Figure 8: SeNB system information acquisition

## 6.4 SeNB radio resource management

The SeNB is primarily responsible for allocating radio resources of its own cells. At least one special cell in the SCG has configured uplink with PUCCH resources. Inter-eNB coordination is needed for UE capabilities, cell/bearer management, QoS requirements, etc. Information is exchanged through RRC containers carried in X2 messages and both eNBs can understand each other's radio resource configurations. The MeNB does not modify the contents in the RRC container of the SeNB.

Generally, the following procedures can be used:

### SeNB (SCG) addition/modification procedure:

Figure 9 shows this procedure.

- The MeNB sends the SCG Addition/Modification Indication message including the MeNB (MCG) configuration.
- The SeNB responds with SCG Addition/Modification Request messages including its radio resources configurations in the RRC container. SeNB also allocates an independent C-RNTI for SCG.
- The MeNB sends the *RRCConnectionReconfiguration* message to the UE including configurations of both the MCG and the SCG.
- The UE applies the new configuration and reply the *RRCConnectionReconfigurationComplete* message to the MeNB.
- The MeNB replies the SeNB SCG Addition/Modification Confirm message to the SeNB forwarding *RRCConnectionReconfigurationComplete* message.
- The UE may perform random access procedure for uplink synchronization with the SeNB.

SeNB can also independently initiate the SCG Modification Request message to perform configuration changes of the SCG.

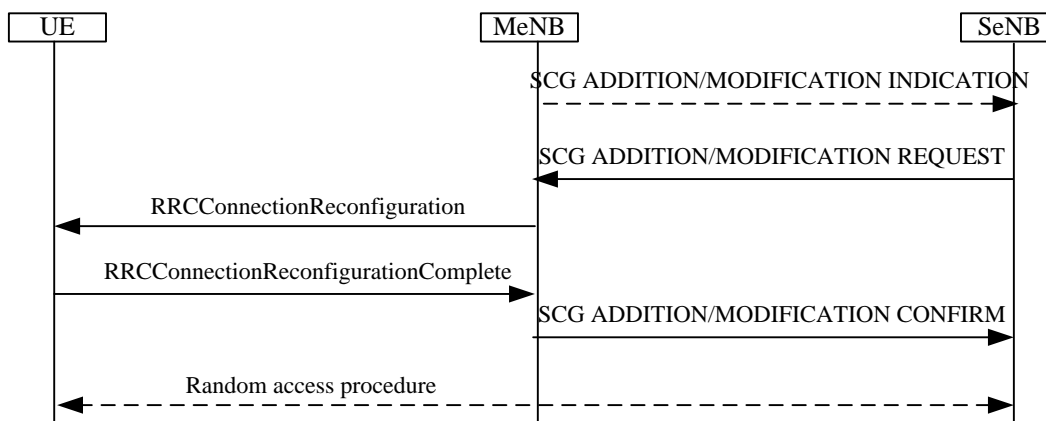

Figure 9: SCG Addition/Modification procedure

### SeNB (SCG) Release procedure:

The SCG release procedure can be realized by the SCG Modification procedure. The *RRConnectionReconfiguration* message comprises the release of the SCG. This part of message may be generated by the MeNB or the SeNB.

**SeNB (SCG) Change procedure:**

The SCG change procedure can be realized by the SCG Addition/Modification procedure. The *RRConnectionReconfiguration* message comprises the release of the source SCG and the addition of the target SCG.

## 6.5 Selection of connection at the UE

In release 12 LTE DC, it is the MeNB who decide which SeNB as additional connection for the UE based on UE's measurement report. In future releases, it is a potential candidate or migration path to have the UE to decide which SeNB to connect with. In choosing which eNB to connect to in the small-cell environment, UE stands in a unique position to make a decision. Given the heterogeneity of the small-cell both in terms of size (macro/pico/femto), and access technology, such decision could depend on complex set of data. The quality of wireless signal, can be best measured at the UE, the battery usage of UE is an important point to consider, and the running application and the device spec have significant effect on the perception of quality of the connection at the UE. In this line, UE can employ range of Multi Attribute Decision Making processes to select the eNB(s) to connect to, not only based on signal strength, but number of rather more important criteria.

### 6.5.1 Use of Analytics

Having UE in control of the connectivity in the LTE DC, the network congestion information could significantly affect the connection experience since performance of good quality wireless channel could be degraded by a congested backhaul link, or the access. To this end, cell-level congestion based on historical analysis of weekly or daily trends could help the UE in choosing the right eNB(s) for its connection. Such analytics can be delivered to the UE through standard S2c interface.

## 6.6 UE capability handling

In LTE DC, the MeNB and the SeNB schedule the same UE independently. UE radio access capabilities may be exceeded if both eNBs exert their radio resources to the UE simultaneously without any coordination. These UE capabilities mainly concern UE specific RF parameters defined by UE category and they may need to be split between the MeNB and the SeNB, e.g., Maximum number of DL-SCH transport block bits received within a TTI, Total number of DL-SCH soft channel bits, Maximum number of UL-SCH transport block bits transmitted within a TTI, etc. In addition to the UE capability parameters, the QoS parameter UE-AMBR should also be considered. It is the maximum aggregated bit rate of all non-GBR bearers of a UE. If a non-GBR bearer is split, UE-AMBR will be enforced across eNBs. It is difficult to coordinate UE capability distribution in real time due to latency of non-ideal backhaul. For coordination and split of the UE capability parameters, the MeNB is an appropriate node to decide the split ratio. MeNB can grant a part of the UE capability i.e., provide UE capability restrictions to the SeNB. MeNB can obtain SeNB capability information, cell configuration, radio condition, load conditions etc via X2 interface, it can estimate the SeNB acceptable UE capability constraints. MeNB and SeNB can also coordinate UE capability split parameters, e.g. SeNB may suggest its acceptable constraints and inform the MeNB to modify the parameters.

## 6.7 SeNB radio link failure handling

When UE detects radio link failure (RLF) in the SeNB, e.g. maximum number of RACH attempts failure, maximum number of RLC PDU retransmissions failure, physical layer link problems etc, it should report the failure to the MeNB and stop all uplink transmissions. The MeNB may initiate SeNB release or SeNB change procedure or temporarily disable the SeNB.

## 7. User plane handling

### 7.1 UL-DL split

UL-DL imbalance refers to the situation that the UE's best uplink cell and best downlink cell are different due to significant transmission power difference between the macro eNB and the small eNB, as depicted in figure 10. UL-DL imbalance issue exists in LTE DC and it is less severe in inter-frequency case than in intra-frequency case because cell edge interference may be significant in the latter case. UL-DL split scheme can reduce cell edge interference for intra-frequency case and save UE power for both cases.

In this scheme, UE selects the node as uplink to which the UL path loss is lower and selects the node as downlink from which the downlink reference signal receiving power (RSRP) is higher. The eNB determines the downlink cell edges and uplink cell edges of the involved cells separately for the UE. Due to backhaul latency, the physical layer control signals and UCIs may still need to be bound with the same eNB, e.g. small eNB allocates UL resources for the UE and transmits PHICH in response to the UL transmissions if UE uplink traffics are targeting the small eNB.

It is observed that good performance can already be achieved with appropriate CRE and ABS configurations in the co-channel Hetnet deployment. Therefore UL-DL split is deprioritized in SCE SI and may be further studied in the future.

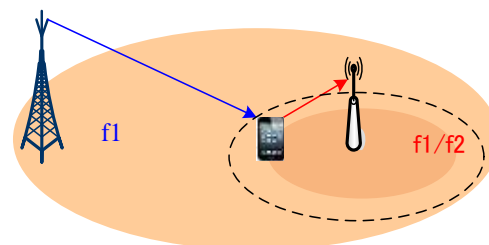

Figure 10: UL-DL split

### 7.2 UL bearer split

In UP 3C, UL bearer split introduces some complexity to the handling of buffer status report (BSR), logical channel prioritization (LCP), power headroom report (PHR), etc. It is possible that the UL bearer is not split even though the corresponding DL bearer is split. By this means, UL user traffic are only targeted to one specific eNB and it can be configured by the network. Consequently, BSR except for BSR for RLC status report, LCP enforcement are only addressed to the configured eNB. However, RLC status reports in response to DL RLC PDU transmissions are still transmitted to the concerned eNB. DL bearer split is supported in release 12 LTE DC and UL bearer split is postponed to future releases.

### 7.3 UCI transmission of SeNB

In Rel-10 and Rel-11 CA, PUCCH is configured only on the PCell. Uplink control information (UCI) e.g. HARQ ACK/NACK, CSI information of SCells are transmitted on PUCCH of the PCell if not piggybacked on SCell's own PUSCH. In LTE DC, it is not suitable any more to carry UCIs of SeNB in PUCCH of PCell in MeNB due to backhaul latency. Therefore, PUCCH is configured on a special SCell of SeNB, i.e. the PSCell. This PSCell is never deactivated and RACH procedure needs to be initiated upon its initial configuration.



## 7.4 PDCP handling

Several challenges exist for PDCP operation in UP 3C: Out-of-order arrival of PDCP PDUs, X2 loss and PDCP PDU SN gap due to PDCP discard functionality etc. To address these issues, PDCP reordering needs to be always on, unlike that in legacy LTE system in which PDCP reordering is only needed upon handover and RRC re-establishment. Timer based reordering can be used to avoid too much latency. This means that PDCP receiving side is allowed to move on window regardless of the gap upon reordering timer expiry. The loss may be caused by X2 congestion or PDCP discard at the transmitting side. Based on this scheme, the RLC-UM like window operation is utilized by PDCP, this can avoid complexity of legacy MRW (move receiving window) like mechanisms in UMTS if RLC-AM like window is used.

## 7.5 RLC handling

For UP 1A, a radio bearer is either located on the MeNB or the SeNB. RLC transmissions/receptions will not occur across eNBs. No special handling is needed. It is also the case for UP 3C. Two logical channels corresponding to the split bearer are located on the MeNB and the SeNB respectively. A RLC entity only belongs to the MeNB or the SeNB and it will not operate across eNBs. If UL bearer is not split, RLC status reports in the uplink are still sent to the corresponding eNB.

## 7.6 UE MAC entity modeling

In UP 1A, dual MAC entity modeling is feasible because the eNB specific bearers are not multiplexed together in UE MAC. In UP 3C, both single and dual MAC entity modeling are applicable from the implementation perspective. The dual MAC entity modeling is adopted not only because a unified modeling is beneficial from the specification perspective, but also because it is clearer and simpler for the operations of the split bearers, e.g. logical channel group mapping to the MCG and the SCG, BSR and LCP procedures etc. The serving cells associated with the MeNB are configured as a MCG (master cell groups), and the serving cells associated with the SeNB are configured as a SCG (secondary cell group). The dual MAC entities of the UE are corresponding to the MCG and the SCG respectively.

## 7.7 Random access

In legacy CA, only one random access procedure is ongoing at any point in time. UE has to monitor PDCCH on PCell during RAR (random access response) window of PCell to receive RAR of random access procedure for a SCell. Contention based RA is not support for SCell.

In LTE DC, existing rules may not be that reasonable any more due to backhaul latency. MeNB or SeNB may not be aware that a RA procedure is being ongoing when it initiates a new RA procedure. Contention based RA procedure may be ongoing when an eNB initiate a contention free RA procedure. If UE ignores one of the RA attempts, unnecessary latency will be introduced. Therefore support of parallel RA procedure has some qualifications. Contention based RA for SeNB is also beneficial to reduce latency, e.g. in case of high priority uplink data arrival in SeNB specific bearers or maximum number of SR (scheduling request) transmissions failure. Contention free based RA for SeNB can be triggered by DL data arrival and addition of the first special SCell with PUCCH.

During the parallel RA procedure, RA preamble transmissions and/or msg3 transmissions may collide or not. In case of colliding, power limitation issue may occur, and some priority rules may be needed, e.g. prioritize PDCCH triggered RA or RA on MeNB etc. In release 12 LTE DC, parallel RA procedure is only supported in case the preamble transmissions do not collide. For RA procedure in the SeNB, UE needs to monitor PDCCH of SCell on the SeNB to receive RAR which requires support of PDCCH common search space for SeNB. This will increase number of UE blind detections.

## 7.8 BSR procedure

It is natural that buffer status of eNB specific bearers is only reported to the corresponding eNB in UP 1A. For a split bearer in UP 3C, two corresponding logical channels locate on the MeNB and the SeNB respectively. RLC entities are logical channel specific so that buffer status in RLC is reported to the corresponding eNB for both logical channels of the split bearer. Buffer in the PDCP entity is shared by both logical channels and in order to avoid double counting, a split ratio needs to be configured. The UE calculates PDCP buffer size in the BSR for the MeNB and the SeNB according to the configured ratio, as shown in figure 11. When overall data amount is small, it may not be efficient to be scheduled by both eNBs. A threshold can be configured to the UE such that UE only needs to report BSRs to both eNBs when the threshold is crossed. UE can report BSR to an configured eNB when data amount is less than this threshold. In release 12 LTE DC, the UL bearer does not split and the MeNB will configure the UE to which eNB the PDCP PDUs will be delivered, so that the BSR for data packets is only reported to the configured eNB. For the other eNB, UE only transmits BSR containing buffer size of reverse RLC status report for the split DL bearer.

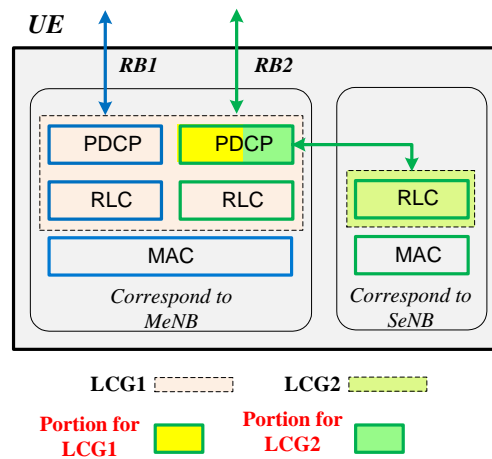

Figure 11: buffer status report

## 7.9 LCP procedure

In legacy LTE releases, token bucket algorithm is used for logical channel prioritization (LCP) procedure. In UP 1A, it is natural that independent LCP procedures per eNB can be applied, as the bearers are eNB specific. However, there is some correlation between LCP for the MeNB and for the SeNB for a split bearer in UP 3C. Two kinds of token bucket modeling can be considered: common token bucket modeling and separate token bucket modeling. For both models, the PBR (prioritized bit rate) of the original split bearer needs to be divided by a configured ratio between the corresponding logical channels, otherwise the PBR of a split bearer may be enforced twice which results in unfair resource allocation.

In the common token bucket modeling, two logical channels of the split bearer share the same token bucket and the bucket size reuses that for the original bearer. Tokens are increased for each TTI at the rate of PBR of the original bearer, and decreased the sizes of each MAC SDU generated for the MeNB and for the SeNB. A sequential PBR enforcement mechanism may be needed because the common variable  $B_j$  for real time tokens can only be decreased mutually exclusive by the MeNB and the SeNB in any TTIs. Figure 12 depicts such common token bucket modeling.

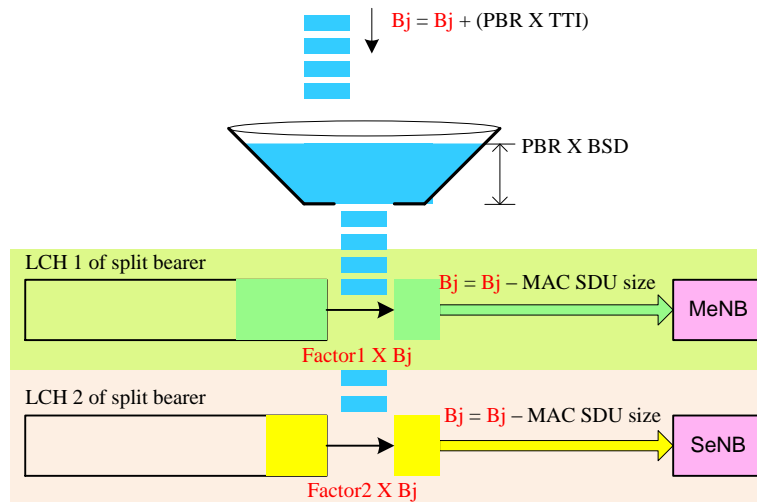

Figure 12: common token bucket modeling

In the separate token bucket modeling, each logical channel maintains its own token bucket independently. The increasing rate of tokens for each bucket is according to its split rate of PBR, tokens are decreased by the size of MAC SDUs generated for the corresponding eNB independently. This model supports parallel PBR enforcement operation.

For both token bucket modeling, ambiguous resource utilization still exists from the eNB perspective. For example, MeNB is not aware of the amount of MAC SDUs UE generates using radio resources of SeNB, and MeNB may still allocate radio resources for the served data until an updated BSR is received. Further optimization may be considered by utilizing coordination between eNBs or indication from the UE.

In release 12 LTE DC, the UL bearer does not split and the separate token bucket modeling is adopted. Starvation of RLC status report may occur if common token bucket model is utilized. The common tokens may be exhausted for multiple consecutive subframes by the logical channels uplink towards the configured eNB for which PDCP data are delivered.

## 7.10 PHR procedure

In CA, the power headroom report (PHR) contains PH information and cell P<sub>max</sub> information of the PCell and all the activated SCells. If simultaneous PUCCH and PUSCH transmission is configured, type II PH of the PCell shall also be included. Type II PH concerns the power headroom considering power consumed by the PUCCH and the PUSCH altogether.

In LTE DC, PHR to either eNB still includes PH and cell P<sub>max</sub> information of the PCell and all the activated SCells. Type II PH of PSCell of SeNB also needs to be included because there is an additional PUCCH in the SeNB. To reduce probability of too aggressive or too pessimistic resource allocation situation, PH and cell P<sub>max</sub> information of cells in the other eNB is useful for the eNB who received the PHR to evaluate the pathloss and resource utilization status of the other eNB. This requires PHR be conveyed to both eNBs if it is triggered according to triggering conditions of either eNB. The radio conditions and pathloss variation characteristics may be quite different for cells of the MeNB and cells of the SeNB, hence the different PHR related parameters can be configured for the MeNB and the SeNB. PHR can be triggered independently for the MeNB and the SeNB, and once triggered for either of the eNBs, it can be transmitted to both eNBs or only one of the eNBs depending on whether UL resources are available. For the PHR of the activated cells belonging to another CG/eNB, UE is configured to report always virtual PH or actual PH when there is a PUCCH/PUSCH transmission for a cell in the other CG, otherwise virtual PH. For UE's uplink transmission towards MeNB and SeNB, MeNB decides the minimum guaranteed power allocation P<sub>MeNB</sub> and P<sub>SeNB</sub>, and informs SeNB these parameters via inter-eNB RRC container.

## 7.11 DRX

It is difficult to inherit common DRX principle of CA for all serving cells due to backhaul latency. The MeNB and the SeNB cannot obtain each other's cell status in time. Per eNB common DRX can still be used in which UE follows common DRX operation for all cells of the same eNB. It is still possible to align DRX on duration time, i.e. the point in time when UE re-enters active time from the inactive period. This can be achieved by exchange of the DRX parameters configuration between the MeNB and the SeNB.

## 7.12 Multi-Path TCP support

Since single application's data can be delivered through multiple connection, and more specifically the UL and DL may have been split over multiple connections, there is a need to support multiple latency and out of order packet delivery. One of the best solution that can deal with such cases is multipath TCP. While the support for multipath TCP is available in today's stack, linking such multipath flows to the dual wireless connectivity is missing, and is important to be considered in the future releases of dual connectivity in LTE.

## 7.13 Activation/deactivation

SCells are allowed to be activated / deactivated by the corresponding eNB. There will be no activation / deactivation operation across eNBs since the cell status cannot be known in time by the concerned eNB due to backhaul latency if its cells are cross activated / deactivated by the other eNB. There is a special cell with PUCCH in the SeNB which will always be activated upon configuration.

# 8. Potential enhancements in future releases

This white paper provides a brief introduction of the LTE DC WI in 3GPP. In future releases of LTE, some potential enhancements may be further expected:

- Support UL bearer split
- Introduction of small cell controller
- Support LIPA/SIPTO in dual connectivity
- Support of CSG in dual connectivity
- Enhancement of Location Information Reporting for dual connectivity
- RRC diversity
- Small cell deployed on unlicensed spectrum or licensed shared access spectrum
- Support of more connections, e.g. three or more
- Combination with multi-path TCP

The forthcoming 5G study items may start in 3GPP from release 14. RAN architecture will be further evolved, e.g. small cells will be ultra densely deployed. UE may have multiple connection paths towards the RAN, e.g. connections with multiple antennas of a centralized RAN, or with multiple small eNBs. The backhauls are also wireless e.g. in millimeter wave band, and may be shared with access links. The air interface will be more flexible and scalable, e.g. support of multiple different air interfaces in a single cell with filtered OFDM techniques. The air interfaces are adapted to different service requirements in a unified infrastructure, e.g. different frame structure and multiple access schemes for H2H communications and industrial M2M communications which needs ultra low latency and very high reliability.

# 9. Summary

LTE DC is a technology to extend CA and CoMP to inter-eNB with non-ideal backhaul, LTE release 12 focuses on inter-eNB CA case for per UE throughput improvement and mobility robustness. The gain of throughput and mobility comes from multiple streams and maintaining single RRC connection. The system architecture, mobility, inter-eNB RRM coordination, user plane handlings etc are the key technical issues.

## 10. References

- [1] RP-122033: "New Study Item Description: Small Cell enhancements for E-UTRA and E-UTRAN – Higher layer aspects".
- [2] RP-132069: "New Work Item Description: Dual Connectivity for LTE".
- [3] RP-130847: "New Study Item Proposal: Study on CoMP for LTE with Non-Ideal Backhaul".
- [4] TR 36.842: "Study on Small Cell Enhancements for E-UTRA and E-UTRAN – Higher layer aspects".
- [5] R2-144660: "Introduction of Dual Connectivity", LTE stage 2 CR for TS 36.300

## Imprint

Wireless World Research Forum  
c/o Format A AG  
Pfingstweidstrasse 102b  
CH-8005 Zürich

Secretariat:  
Vinod Kumar  
Alcatel-Lucent France  
Centre de Villarceaux  
Route de Villejuste  
91 620, NOZAY  
France  
e-Mail: [vinod.kumar@alcatel-lucent.com](mailto:vinod.kumar@alcatel-lucent.com)  
Phone : + 33 1 30 77 27 37  
Fax : + 33 1 30 77 61 75

The WWRF is a non-profit organisation registered in Switzerland

Chairman of the Forum:  
Dr. Nigel Jefferies

Editor-in-Chief: Mr Sudhir Dixit

The WWRF **Outlook** Visions and research directions for the Wireless World

ISSN 1662-615X is published non-periodically by the Wireless World Research Forum  
<http://www.wwrf.ch>

Responsibility for the contents rests with the Steering Board of the Forum.